

Isolated Barrier

GS5035-EX
GS5036-EX

GYB20.1432



Please read the user manual carefully before using the product, and please keep it properly for further reference.

Caution

- Please check whether the product type on the package accords to the ordering contract;
- Read this manual carefully before installation or use. If there is something unclear, please contact technical support;
- Isolated barrier should be installed in the safe area;
- Supply voltage is 24VDC, 220VAC is forbidden;
- It is strictly forbidden to disassemble the barrier to prevent from failing or malfunction.

CZ.GS5036-EX.11(S)E-6.0/19.11

Connections

- (1) This barrier adopts a pluggable connector with screw terminals. The intrinsically safe(IS) terminals (blue plugs) should be connected to hazardous area devices and the non-IS ones (green plugs) to the safe area devices.
- (2) Choose for the hazardous area the blue-marked wires. Its minimum cross-section area should be 0.5mm², and the minimum dielectric strength should be 500V.
- (3) The wirings in the safe area and the hazardous area must be separated, and both have protection bushes.
- (4) A length of 7mm bared wire is locked by the M3 bolt. See as shown below.

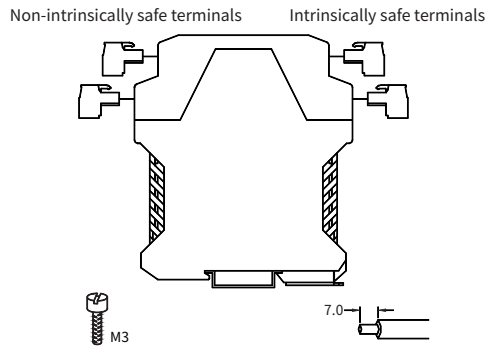

Installation

The isolated barrier should be installed in the safe area, according to the related requirements in GB 3836.13-2013, GB/T 3836.15-2017, GB/T 3836.16-2017, GB/T 3836.18-2017, GB 15577-2018 and GB 50257-2014.

The isolated barrier is designed for mounting on 35mm DIN rail. Installation procedure:

- (1) Hook the backplane of the barrier into the top of the rail;
- (2) Press downward.

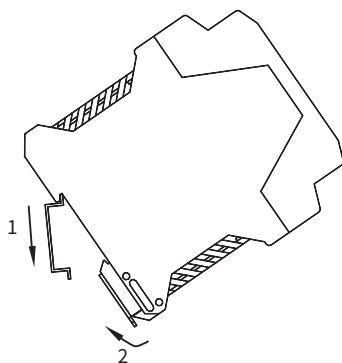

Disassembly

- (1) Insert a screwdriver (its edge length ≤ 6mm) into the downside metal lock of the barrier;
- (2) Push the screwdriver upwards, then prize the metal lock downwards;
- (3) Take the barrier out of the rail.

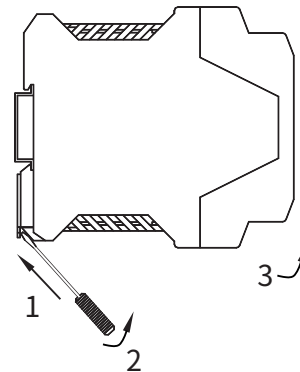

Maintenance

- (1) Before using, please check again whether the product's model and Ex-proof rating are consistent with the operation conditions; whether the wiring and polarity are correct.
- (2) It is disallowable to test the insulation among the terminals with a megameter. The wiring must be disconnected before testing the insulation of the system, otherwise the internal fuse would blow.
- (3) Every product has been strictly tested before leaving factory. If product does not work properly, please contact the nearest agent or CHENZHU technic support.
- (4) In 5 years from the delivery date, if the product works improperly during normal operation, we will repair or replace it without payment.

SHANGHAI CHENZHU INSTRUMENT CO.,LTD.



Add: Building 6, 201 Minyi Road, Caohejing Hi-Tech Park
Songjiang New Industrial Park, Shanghai 201612, P.R. China
Tel : +86-21-64513350 Fax : +86-21-64846984
Email: chenzhu@chenzhu-inst.com
<http://www.chenzhu-inst.com>

■ Summarize

2-wire HART transmitter, 3-wire transmitter, current source input isolated barrier, provides isolated supply for transmitters which located in hazardous area. This product transfers 4~20mA signal which generated by the transmitter (or current source signal) from hazardous area to safe area separately, also allows bi-directional transmission of HART signals. The product needs an independent power supply and galvanic isolation among power supply, input and output.

■ Specification

Number of channels: 1/2(GS5035-EX)
2(GS5036-EX)

Supply voltage: 20~35V DC

Current consumption: (at 24Vdc supply, 20mA output)
≤75mA (GS5035-EX)
≤100mA (GS5036-EX)

Safe-area output:

Current: 0/4~20mA, HART digital signal
Load resistance: $R_L \leq 300\Omega$

Voltage: 0/1~5V, HART digital signal
Load resistance: $R_L \geq 330k\Omega$

Note: Users need specify current or voltage output when ordering.

Hazardous-area input:

Current: 0/4~20mA, HART digital signal
Distribution: Open circuit voltage: $\leq 28V$
Voltage at 20mA: $\geq 15.5V$

Rating current: $\leq 25mA$

Transfer accuracy: 0.1%F.S. (Typical: 0.05%F.S.)

Temperature drift: 0.005%F.S./°C

Response time(0~90%): $\leq 2ms$

Power supply protection: Power supply reverse protection

EMC: According to IEC 61326-1(GB/T 18268)

Dielectric strength:

Between non-IS part and IS part $\geq 2500VAC$

Between power supply part and output part $\geq 500VAC$

Insulation resistance:

Between non-IS part and IS part $\geq 100M\Omega$

Between power supply part and output part $\geq 100M\Omega$

Weight: Approx.100g

Suitable location: Mounting in safe area, and connected to the IS apparatus in hazardous area up to zone 0 IIC and zone 20 IIIC.

Suitable field apparatus:

2-wire HART transmitter, 3-wire transmitter, current source

■ Ambient Conditions

(1) There should be no following substances in the air: flammable and explosive substances; medium that could corrupt the coat of chrome, nickel and silver. Moreover, please avoid using this product in violent quiver, impact or strong electromagnetic interference environment.

(2) Operating temperature: $-20^{\circ}C \sim +60^{\circ}C$

(3) Storage temperature: $-40^{\circ}C \sim +80^{\circ}C$

(4) Relative humidity: 10%~90%

■ Intrinsic Safety Certification

Certifying authority: NEPSI (China)

Conformity standards: GB3836.1, GB3836.4, GB3836.20, GB12476.1

and GB12476.4

Ex marking: [Ex ia Ga] II C, [Ex iaD]

Maximum voltage: $U_m = 250V$

Intrinsic safety parameters: (7, 8, 9; 10, 11, 12 terminals)

$U_0 = 28V$, $I_0 = 93mA$, $P_0 = 651mW$

II C: $C_0 = 0.083\mu F$, $L_0 = 4.2mH$

* II B: $C_0 = 0.65\mu F$, $L_0 = 12.6mH$

II A: $C_0 = 2.15\mu F$, $L_0 = 33.6mH$

Note: * II B parameters are also applicable for combustible dust atmospheres.

When using the values of maximum external capacitance (C_0) and inductance (L_0), please attend the following requirements:

(1) For circuits only containing distributed capacitance and distributed inductance, e.g. cable, allow the values of C_0 and L_0 in accordance with the allowed values in the certification parameters;

(2) For circuit combined with IS circuit and cables, if the inductance or capacitance of IS circuit are no greater than 1% of the respective parameters, then the permissible maximum external output parameters of capacitance and inductance in accordance with the allowed values in the certification parameters;

(3) For circuit combined with inductance and capacitance, if both parameters are greater than 1% of the output parameters (excluding cables), then the permissible maximum external output parameters of capacitance and inductance should be 50% of the allowed values in the certification parameters.

■ Intrinsic Safety Explosion Protection System

Special requirements have to be confirmed before using the intrinsically safety explosion protection system (intrinsically circuit) which connected by isolated barrier and intrinsically safe apparatus in field:

(1) The EX-proof level of intrinsically safe apparatus should meet the requirements of operation conditions. The apparatus should pass the explosion protection test and get the certificate by authorized explosion-proof product certification bodies.

(2) The intrinsic safety parameters of isolated barrier and intrinsically safe apparatus both are clear, and comply with GB/T 3836.15.

(3) If any parameters are unclear, the system has to be confirmed by authorized explosion-proof product certification bodies.

■ Application

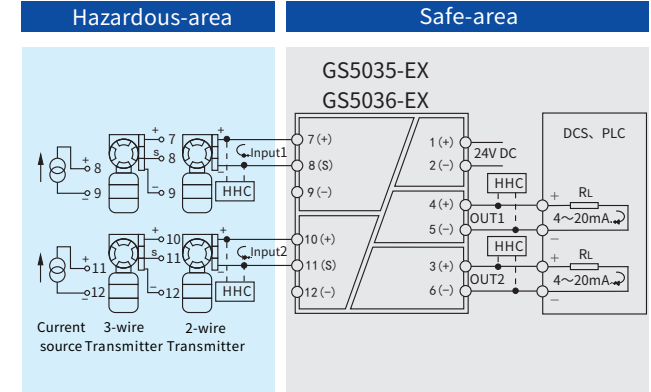

Note: 1. GS5035-EX only contains input 1, output 1 and output 2.

2. It is not allowed to use HHC (HART hand-held communicator) in hazardous area and safe area at the same time.

3. HHC used in hazardous area must get an EX-proof certification.

■ Dimensions

114.5mm × 99.0mm × 17.5mm

