

Isolated Barrier

GS8272-EX.AMR
 GS8272-EX.AM
 GS8272-EX.AR
 GS8272-EX.MR

GYB20.2130



Please read the user manual carefully before using the product, and please keep it properly for further reference.

Caution

- Please check whether the product type on the package accords to the ordering contract;
- Read this manual carefully before installation or use. If there is something unclear, please contact technical support;
- Isolated barrier should be installed in the safe area;
- Supply voltage is 24VDC, 220VAC is forbidden;
- It is strictly forbidden to disassemble the barrier to prevent from failing or malfunction.



SHANGHAI CHENZHU INSTRUMENT CO.,LTD.

Add: Building 6, 201 Minyi Road, Caohejing Hi-Tech Park
 Songjiang New Industrial Park, Shanghai 201612, P.R. China
 Tel : +86-21-64513350 Fax : +86-21-64846984
 Email: chenzhu@chenzhu-inst.com
 http://www.chenzhu-inst.com

Specification

Isolated barrier, with single channel temperature input and multifunctional output, convert the input signals into proportional 4~20mA current signal from hazardous area to safe area. It also provides one channel RS-485 output based on MODBUS-RTU protocol and two channels relay output. The power supply and RS485 communication output can be connected via rail. Current and relay output can only be connected via terminals. The product needs an independent power supply and galvanic isolation among power supply, input and output

Specification

Number of channels: 1
 Supply voltage: 20~35V DC
 Current consumption:(GS8272-EX.AMR)≤60mA
 (GS8272-EX.AM)≤50mA
 (GS8272-EX.AR)≤60mA
 (GS8272-EX.MR)≤50mA

Note: Suffix description

“A” ——1 ch 4-20mA output; “M” ——1 ch RS485 output(Modbus RTU),
 “R” ——2 ch relay outputs

Safe-area Signal:

Current Output:4~20mA; Load Resistance:RL≤300Ω
 Sample time: ≤0.8s
 Response Time(0~90%):≤1s
 Transmission Accuracy:0.1%F.S.
 Temperature Drift:0.1%F.S./10°C
 CJC error:±1°C(-20°C~+60°C)

RS485 Output:

Communication Protocol: MODBUS-RTU
 Default Address: 1(Configurable)
 Communication Length:≤1000m
 Number of Slaves:≤32
 Communication parameter: 9.6kbps; Data bit:8; Stop bit: 1;
 Even parity check; Configurable

Response Time:≤1s
 Transmission Accuracy:0.1%F.S.

Relay output:

Number of Channels:2
 Contact Loading:250V AC,2A or 30V DC,2A
 Response Time:≤1s

Alarm indication description:

Instrument Status	LED L	LED H
Normal	OFF	OFF
Underrange	Flashing(slow)	OFF
Overrange	OFF	Flashing(slow)
Output below the lower limit	Flashing(fast)	OFF
Output exceeds the upper limit	OFF	Flashing(fast)
Line break error	OFF	ON
Line shorted error	ON	OFF

- Note:1. When line break error occurs, the default output current is 21mA.
 2. When line shorted error occurs(only RTD), the default output current is 3mA
 3.fault current is configurable.

Input Signal and Range:

Type	Range	Min.Span	Accuracy
T C	T	-200°C~+400°C	50°C 0.5°C/0.1%
	E	-200°C~+900°C	50°C 0.5°C/0.1%
	J	-200°C~+1200°C	50°C 0.5°C/0.1%
	K	-200°C~+1372°C	50°C 0.5°C/0.1%
	N	-200°C~+1300°C	50°C 0.5°C/0.1%
	R	-40°C~+1768°C	500°C 1.5°C/0.1%
	S	-40°C~+1768°C	500°C 1.5°C/0.1%
B	+320°C~+1820°C	500°C 1.5°C/0.1%	
R T D	Pt100	-200°C~+850°C	20°C 0.2°C/0.1%
	Cu50	-50°C~+150°C	20°C 0.2°C/0.1%
	Cu100	-50°C~+150°C	20°C 0.2°C/0.1%

- Note: 1.The “%” of conversion accuracy is relative to its range. Take the larger value between the range error and the absolute error when applying.
 2.Allow a maximum wire resistance of 50Ω/line for RTD input(3-wire).
 3.When the thermocouple is input, the conversion accuracy does not include the C.J.C.For every 100Ω increase in the compensation wire, the cold junction error increases by 0.2°C.
 4.When the Type B thermocouple is input, the temperature range is required to be greater than 680 °C to ensure the accuracy index.
 5.When the Type S thermocouple is input, the temperature measurement accuracy is 0.6% below 10°C
 Power Supply Protection:Power supply reverse protection
 EMC:According to IEC 61326-1(GB/T 18268)
 Dielectric Strength:
 Between non-intrinsically safe part and intrinsically safe part≥2500V AC
 Between power supply part and output part ≥500V AC
 Insulation resistance:

- Between non-IS part and IS part≥100MΩ
- Between power supply part and output part≥100MΩ

Weight:Approx.150g

Suitable Location:Mounting in safe area, and connected to the IS apparatus in hazardous area up to zone 0 IIC and zone 20 IIIC
 Suitable Field Apparatus:RTD,TC

Ambient Conditions

- There should be no following substances in the air: flammable and explosive substances; medium that could corrupt the coat of chrome, nickel and silver. Moreover, please avoid using this product in violent quiver, impact or strong electromagnetic interference environment.
- Operating temperature: -20°C~+60°C
- Storage temperature: -40°C~+80°C
- Relative humidity: 10%~90%

Intrinsic Safety Certification

Certifying authority: NEPSI
 Conformity standards: GB/T 3836.1、GB/T 3836.4、GB 3836.20
 Ex marking: [Ex ia Ga] II C , [Ex ia Da] IIIC
 Maximum voltage: Um=250V

Intrinsic safety parameters: (9, 10, 11terminals)

- Uo=6.6V, Io=5mA, Po=9mW
- II C: Co=22μF, Lo=100mH
- * II B: Co=66μF, Lo=300mH
- II A: Co=176μF, Lo=800mH

Note: * II B parameters are also applicable for combustible dust atmospheres.

When using the values of maximum external capacitance (Co) and inductance (Lo), please attend the following requirements:

- For circuits only containing distributed capacitance and distributed inductance, e.g. cable, allow the values of Co and Lo in accordance with the allowed values in the certification parameters;
- For circuit combined with IS circuit and cables, if the inductance or capacitance of IS circuit are no greater than 1% of the respective parameters, then the permissible maximum external output parameters of capacitance and inductance in accordance with the allowed values in the certification parameters;
- For circuit combined with inductance and capacitance, if both parameters are greater than 1% of the output parameters (excluding cables), then the permissible maximum external output parameters of capacitance and inductance should be 50% of the allowed values in the certification parameters.

Application

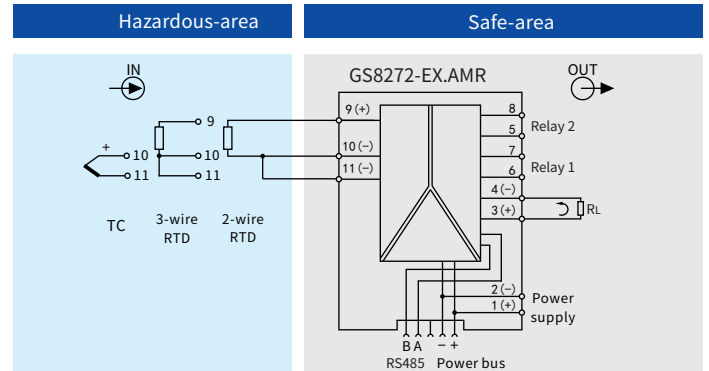

Note: the power bus supply and RS485 bottom output are standard settings.

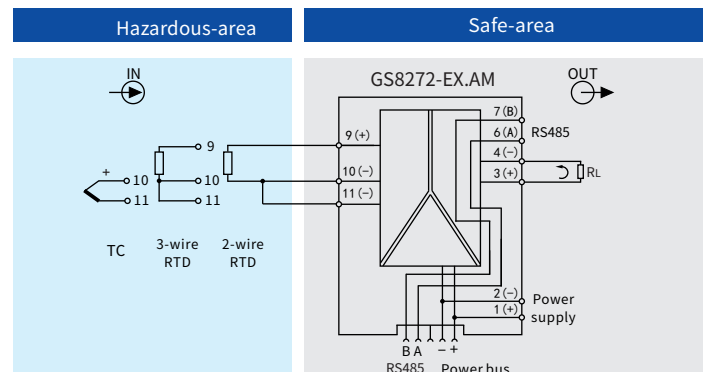

Note: the power bus supply and RS485 bottom output are optional settings.

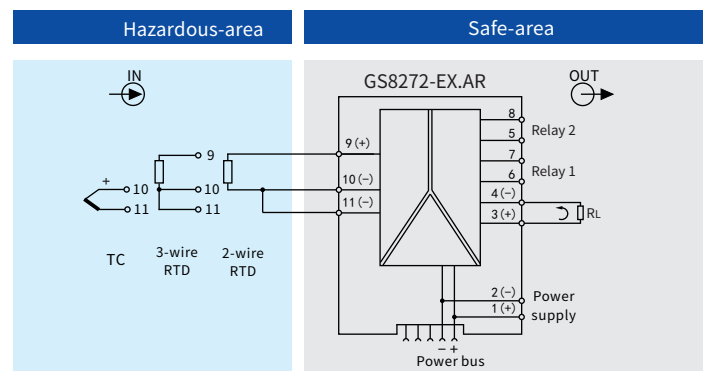

Note: the power bus supply is optional setting.

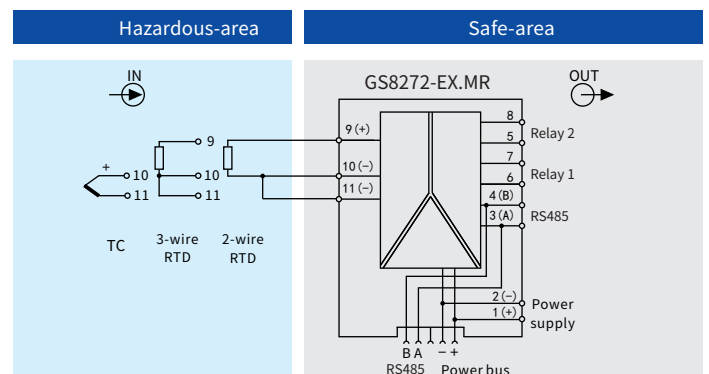

Note: the power bus supply and RS485 bottom output are optional settings.

Relay operation and alarm status

Relay contacts are SPST type. After power on, relays are set to energized or de-energized according to the configuration. Two channels relay output can be individually set to one of seven alarm modes: no alarm, upper trip value without latch, lower trip value without latch, upper and lower trip value without latch, upper trip value with latch, lower trip value with latch, upper and lower trip value with latch. Latching means that when the relay enters the alarm state from a normal state, it remains in the alarm state and needs to be reset through hardware power outage or software.

When the relay is in a non latching state and returns from an alarm state to a normal state, the margin set by this setting value needs to be increased after adding an offset to the input current to prevent the relay from shaking. For the hysteresis of upper trip, the relay will only switch when the output (Input stacking offset) drops from the upper trip value ($T_{out} > \text{upper trip value}$) to the upper trip value minus the hysteresis of upper trip value or below ($T_{out} \leq \text{upper trip value} - \text{hysteresis of upper trip value}$); For the hysteresis of lower trip, the relay will only switch when the output (Input stacking offset) increases from the lower trip value ($T_{out} < \text{lower trip value}$) to the lower trip value plus the hysteresis of lower trip value or above ($T_{out} \geq \text{lower trip value} + \text{hysteresis of lower trip value}$).

Normally open: No trip alarm (relay de-energized)

Trip alarm (relay energized)

Normally close: No trip alarm (relay energized)

Trip alarm (relay de-energized)

Relationship between relay alarm mode and measured value

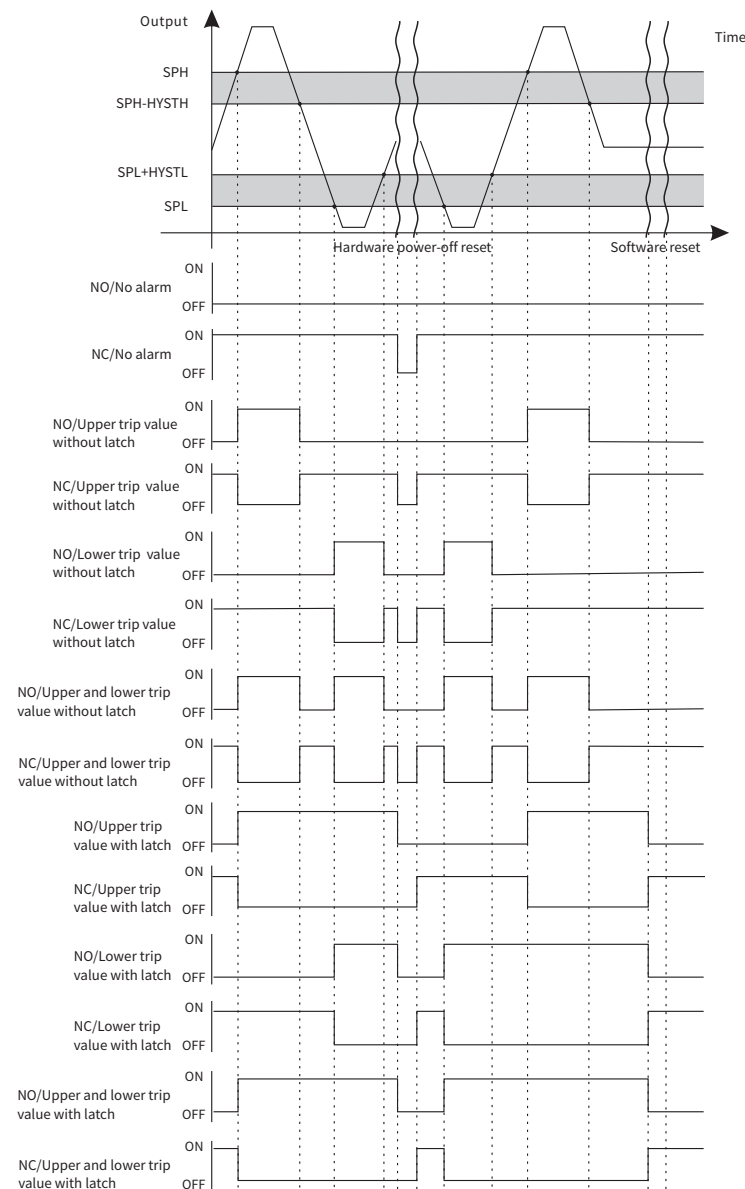

Relay alarm delay

When the relay reaches the switching condition, it does not immediately switch, but instead judges that the fault duration exceeds the set delay time (T) before switching. If the output belows the alarm range during this period, cancel the switching; If the switching conditions are met again in the future, the delay time will be recalculate

Relationship between relay alarm mode and measured value

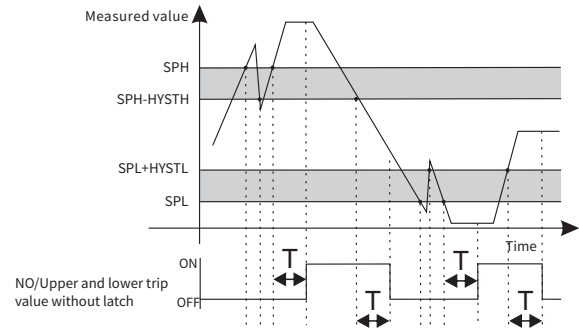

Factory default settings

485	Factory default settings/configurable range
485 baud rate	Default settings: 9600 Configurable range: 300, 600, 1200, 2400, 4800, 9600, 14400, 19200, 38400, 56000, 57600, 115200, 128000
485 check bits	Default settings: Even Configurable range: Even, Odd, None
485 data bits	Default settings: 8 Configurable range: 7, 8
485 stop bits	Default settings: 1 Configurable range: 1, 2
Slave address	Default settings: 1 Configurable range: 1~32

Input	Default settings/configurable range
Sensor type	Default settings: Pt100(0~200°C) Configurable range: Pt100(-200°C~+850°C), Cu50(-50°C~150°C), Cu100(-50°C~150°C), R-TC(-40°C~1768°C), K-TC(-200°C~1372°C), E-TC(-200°C~900°C), T-TC(-200°C~400°C), J-TC(-200°C~1200°C), B-TC(320°C~1820°C), S-TC(-40°C~1768°C), N-TC(-200°C~1300°C)
Offset	Default settings: 0°C Configurable range: ±Maximum measurement range*5%
Upper limit	Default settings: 200°C Configurable range: Upper limit of graduation
Lower limit	Default settings: 0°C Configurable range: Lower limit of graduation
Relay upper trip value	Default settings: 175°C Configurable range: Temperature value corresponding to 3.0mA~21.3mA and upper trip value > lower trip value
Relay lower trip value	Default settings: 25°C Configurable range: Temperature value corresponding to 3.0mA~21.3mA and upper trip value > lower trip value
Hysteresis of upper trip	Default settings: 1°C Configurable range: Temperature value corresponding to 3.0mA~21.3mA and upper trip value - hysteresis of upper trip value ≥ 0mA
Hysteresis of lower trip	Factory default settings: 1°C Configurable range: Temperature value corresponding to 3.0mA~21.3mA and lower trip value + hysteresis of lower trip value ≤ 21.3mA

Output	Default settings/configurable range
Rc filter coefficients	Default settings: 90 Configurable range: 0~100
Upper value of the range	Default settings: 20.0mA Unconfigurable
Lower value of the range	Default settings: 4.0mA Unconfigurable
Upper limit clamping current	Default settings: 20.8mA Configurable range: 3.0mA~21.3mA and upper limit clamping current>lower limit clamping current
Lower limit clamping current	Default settings: 3.8mA Configurable range: 3.0mA~21.3mA and upper limit clamping current>lower limit clamping current
Line breakage alarm	Default settings: 21.0mA Configurable range: 3.0mA~21.3mA
Line shorted alarm	Default settings: 3.0mA Configurable range: 3.0mA~21.3mA
Relay 1 alarm status	Default settings: No alarm Configurable range: Seven alarm modes
Relay 2 alarm status	Default settings: No alarm Configurable range: Seven alarm modes
Relay 1 working status	Default settings: NO Configurable range: NO, NC
Relay 2 working status	Default settings: NO Configurable range: NO, NC
Relay alarm delay	Default settings: 0s Configurable range: 0s~300s

■ Intrinsic Safety Explosion Protection System

Special requirements have to be confirmed before using the intrinsically safety explosion protection system(intrinsically circuit) which connected by isolated barrier and intrinsically safe apparatus in field:

- (1) The EX-proof level of intrinsically safe apparatus should meet the requirements of operation conditions. The apparatus should pass the explosion protection test and get the certificate by authorized explosion-proof product certification bodies.
- (2) The intrinsic safety parameters of isolated barrier and intrinsically safe apparatus both are clear, and comply with GB/T 3836.15.
- (3) If any parameters are unclear, the system has to be confirmed by authorized explosion-proof product certification bodies.

■ Dimensions

118.9mm × 106.0mm × 17.5mm

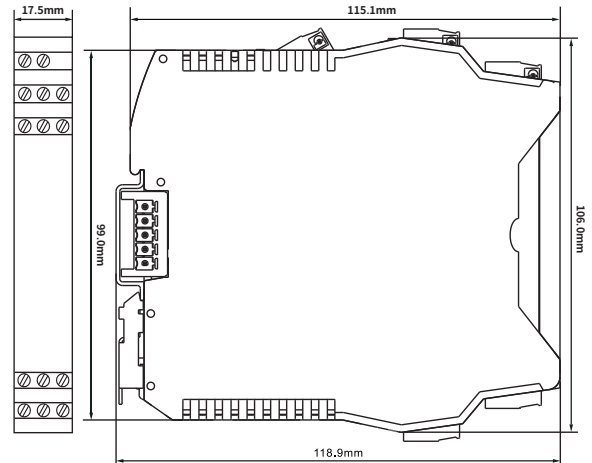

■ Configuration Software: EasyConfig

The configuration software EasyConfig is based on the Windows. It is easy to use for its Human-Machine Interaction and USB interface. The parameters such as the sensor type and range scope can be configured.

Version of operating system: Windows XP ,Windows7 , Windows 10

Hardware interface: MINI-USB

Dedicated adapter: USBCOM-MINI (dedicated USB for RS-232 serial connection)

Note: Users need to power the barrier with external 24V DC when configuring the parameters. Do not power off or plug in or out the programming cable during data download process.

■ Connections

- (1) This barrier adopts a pluggable connector with screw terminals. The intrinsically safe(IS) terminals (blue plugs) should be connected to hazardous area devices and the non-IS ones (green plugs) to the safe area devices.
- (2) Choose for the hazardous area the blue-marked wires. Its minimum cross-section area should be 0.5mm², and the minimum dielectric strength should be 500V.
- (3) The wirings in the safe area and the hazardous area must be separated, and both have protection bushes.
- (4) A length of 7mm bared wire is locked by the M3 bolt. See as shown below.

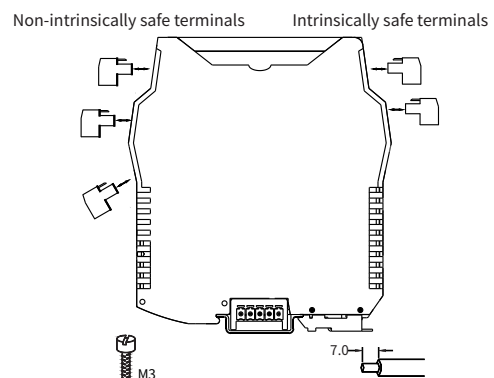

■ Installation

The isolated barrier should be installed in the safe area, according to the related requirements in GB/T 3836.13-2021, GB/T 3836.15-2017, GB/T 3836.16-2017, GB/T 3836.18-2017, GB 15577-2018 and GB 50257-2014.

The isolated barrier is designed for mounting on 35mm DIN rail. Installation procedure:

- (1) Clamp the bus connector on the rail;
(If no bus-powered function, omit this step);
- (2) Hook the backplane of the barrier into the top of the rail;
- (3) Press downward.

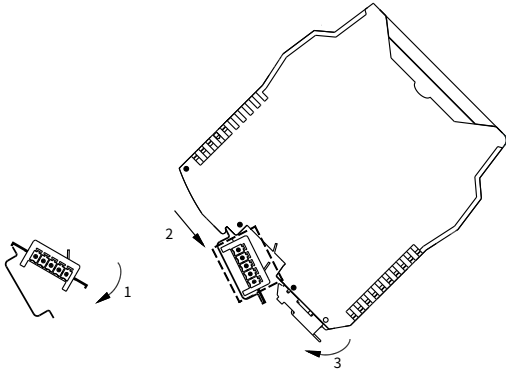

■ Disassembly

- (1) Insert a screwdriver (its edge length $\leq 6\text{mm}$) into the downside metal lock of the barrier;
- (2) Push the screwdriver upwards, then prize the metal lock downwards;
- (3) Take the barrier out of the rail.

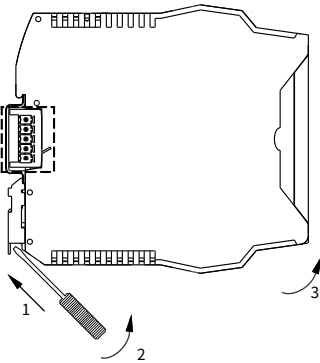

■ Maintenance

- (1) Before using, please check again whether the product's model and Ex-proof rating are consistent with the operation conditions; whether the wiring and polarity are correct.
- (2) It is disallowable to test the insulation among the terminals with a megameter. The wiring must be disconnected before testing the insulation of the system, otherwise the internal fuse would blow.
- (3) Every product has been strictly tested before leaving factory. If product does not work properly, please contact the nearest agent or CHENZHU technic support.
- (4) In 5 years from the delivery date, if the product works improperly during normal operation, we will repair or replace it without payment.